



TRIED, TESTED AND PROVEN PERFORMANCE

The SQ Junior is a super quiet performance pump built to stand the test of time. Ideal for locations where noise is a concern, you can rely on the SQ Junior to keep performing year after year.

• Performance

Model Selection:

Model	Hp Output	kW Output	Min. Suction Pipe Size
SQJ-750	1.0	0.75	40mm
SQJ-1100	1.5	1.1	40-50mm

Maximum recommended number of Poolrite Venturi Spa Jets for each pump at minimal head loss:

SQJ-750	4
SQJ-110	6

Flow Rates:

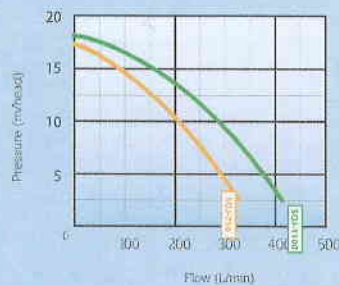

• Features

- Super quiet operation in all installations.
- Performance impellor for efficient operation.
- Commercial grade pump for domestic applications.
- Constructed from durable materials to provide longevity.
- Easy access to lint pot for maintenance and cleaning.
- Clear cover allows full view of operation.
- Carefully designed housing and impellor diffuser for quiet operation.
- 10 year housing warranty.
- Proudly Australian designed & manufactured.
- Quick connect couplings for simple installation.

• Specifications

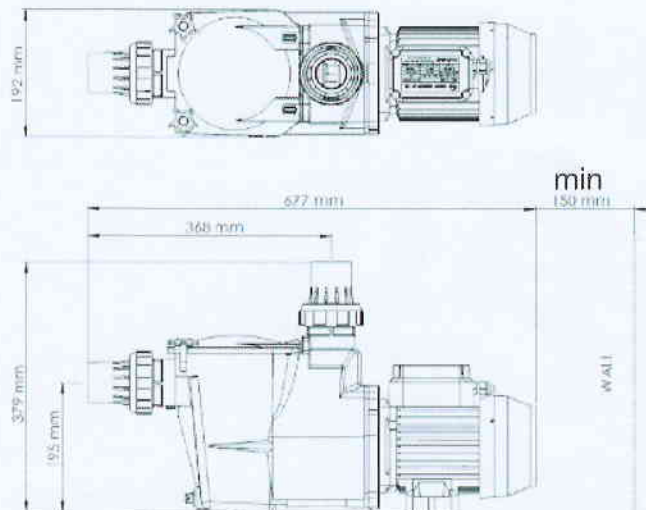

• Warranty



2 Year pump and motor
10 Year housing

MODEL	Weight	Carton Dimension (mm)
SQJ-750	16.6kg	687(L) x 224(W) x 330(H)
SQJ-1100	18.4kg	687(L) x 224(W) x 330(H)

Your local distributor

www.poolrite.com

415 Creek Road, Mt Gravatt QLD, 4122
info@poolrite.com



Proudly Australian
Owned & Made

